

Name: Nathan Powney

Date: 16/10/11

Race Track: Ledbury MCC

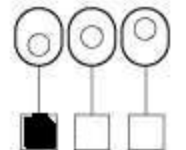
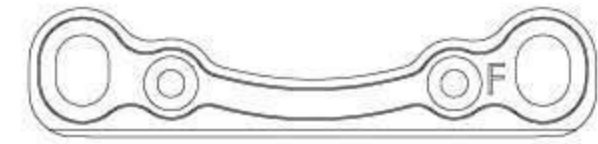
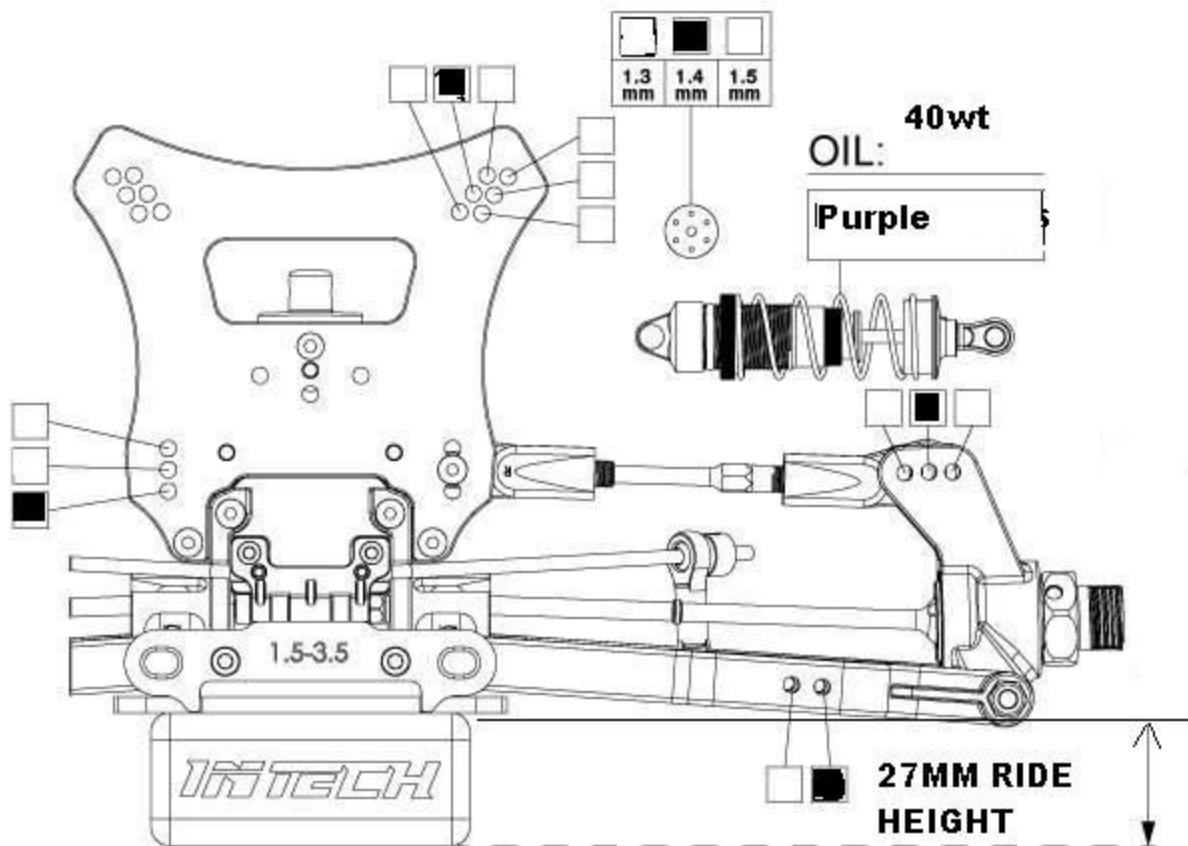
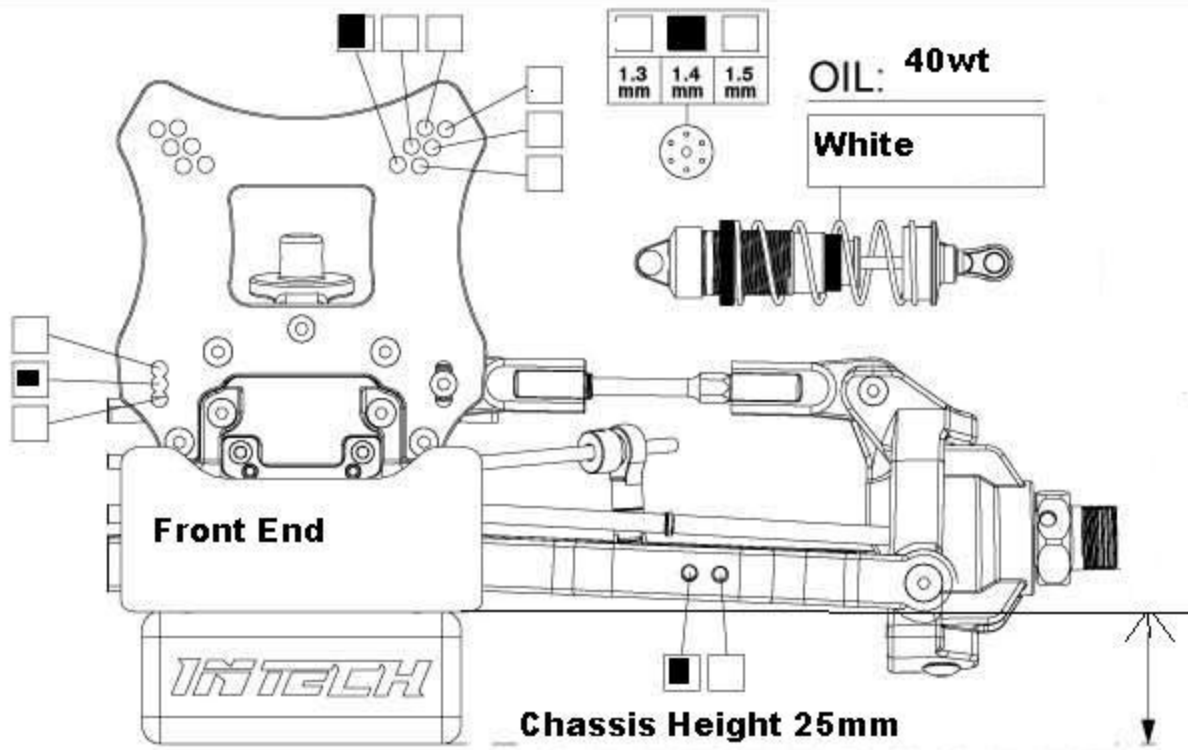

0.5 INSERT

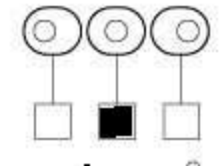

1

set the table angle

Insert	-1	-0.75	-0.5	-0.25	0	0.25	0.5	0.75	1
Angle	0	0.25	0.5	0.75	1	1.25	1.5	1.75	2

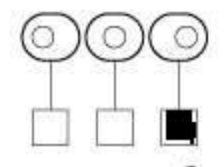
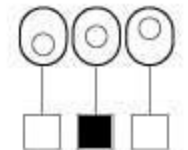

3

set the table angle

Insert	-1	-0.75	-0.5	-0.25	0	0.25	0.5	0.75	1
Angle	1.5	1.75	2	2.25	2.5	2.75	3	3.25	3.5

CAR FULL LENGTH ON WHEELBASE & TRIMMED ARMS FOR EXTRA 2MM LENGTH

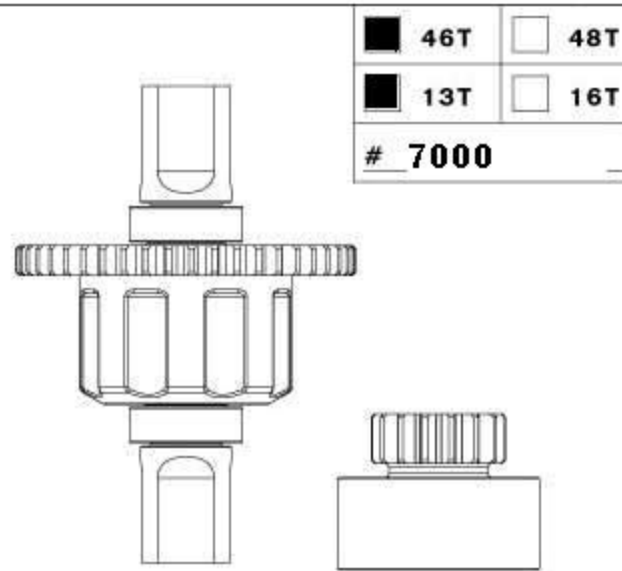
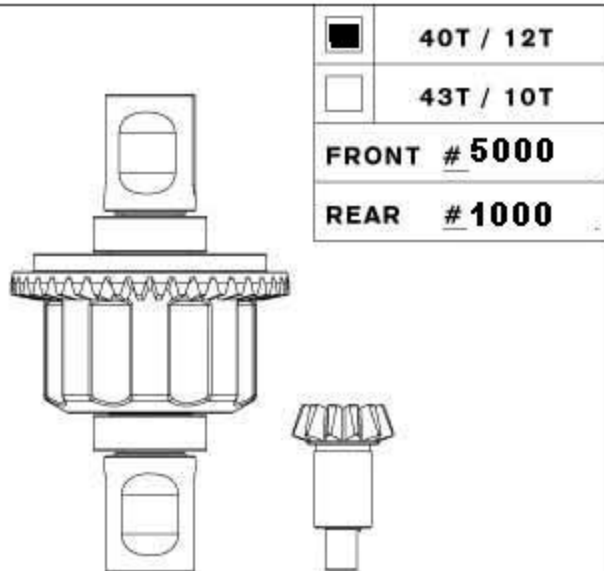

Notes:-

Running 5mm Longer Chassis & Battery Mounted at front next too servo

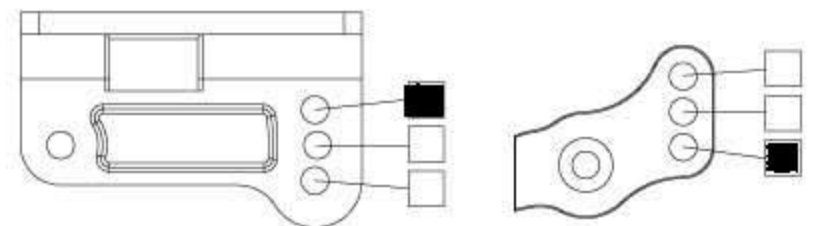

### ANTI ROLL BAR

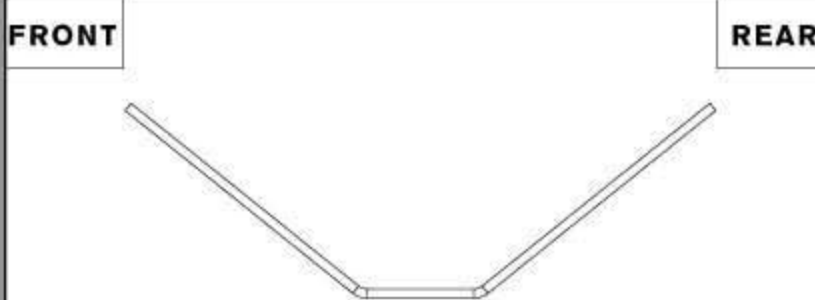

FRONT THICKNESS 2.6  
REAR THICKNESS 2.4  
Ends Flush 3mm In from Ends

### TIRES

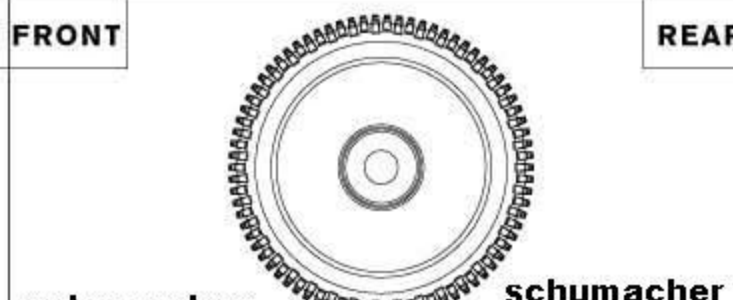

schumacher yellow mini spike  
TYPE INSERTS WHEELS Intech

### ENGINE

TYPE	Werks B6 pro
MANIFOLD	Reedy
MUFFLER	Reedy
PLUG	RB No 6
FUEL	Werks 25%

### BODY

TYPE STOCK